

AQUOS wish5

Model: SH-M32SG

Quick Start Guide

<Prohibited Actions>
 - Do not charge device while it is wet with water or other liquids (drinking water, sweat, sea water, etc.).
 - Do not charge device where exposed to water (bathroom, etc.).

PKSX551061A

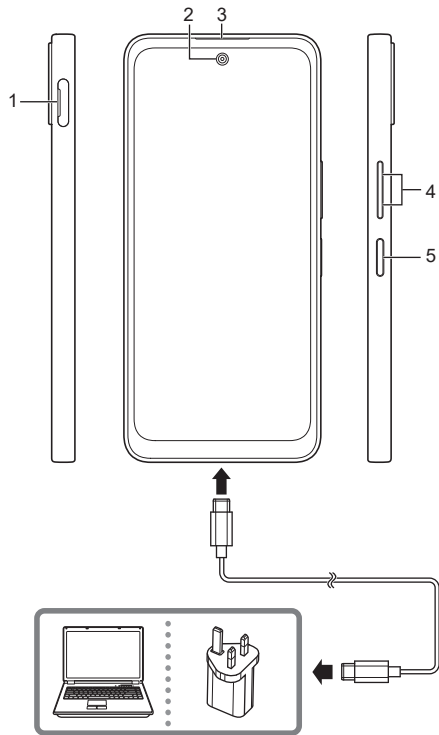
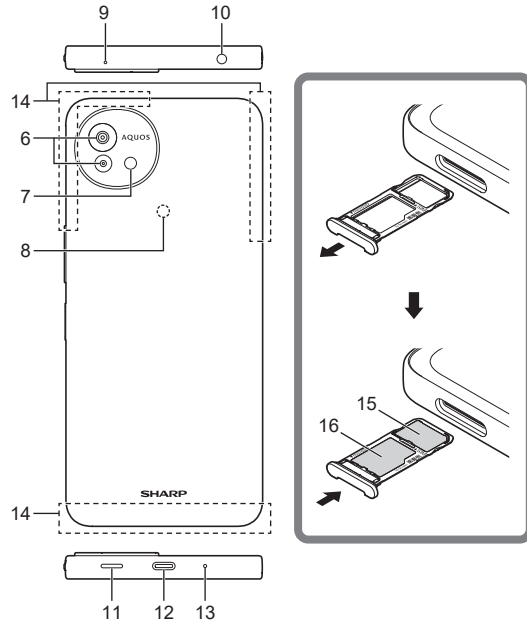

Part Names

- | | |
|---------------------------------|---------------------------|
| 1. nanoSIM/microSD Tray | 11. Speaker |
| 2. Front Camera | 12. USB Type-C™ Connector |
| 3. Earpiece | 13. Microphone |
| 4. Volume Up/Down key | 14. Antenna |
| 5. Power Key/Fingerprint Sensor | 15. nanoSIM Card |
| 6. Rear Camera | 16. microSD Card |
| 7. Mobile Light | |
| 8. NFC | |
| 9. Sub microphone | |
| 10. 3.5mm Earphone Jack | |

Note: * Please purchase nanoSIM Card and microSD Card separately.
 * Since parts that generate magnetism are used in the Earpiece, Speaker, Camera, and Vibrator, please check that no metal pieces (cutter blades, needles) are attached before use. You may cause injury.
 * It is recommended that you charge the battery for at least 30 minutes before starting up your device for the first time.

Important Information

Please read before proceeding

- The device must have security features to prevent unauthorized persons from manipulating this device by making arbitrary changes to the software.
- The device itself is designed for use in Singapore. If the device is to be used overseas, it may violate the laws and regulations of the destination country, so please check before using. This device supports roaming in the Singapore band and throughout Asia, but please check the information issued by the respective telecommunications carriers regarding roaming charges.
- DO NOT place sharp objects on top of the device, as they may scratch the screen.
- DO NOT drop your device or subject it to severe impacts. Bending the body and pushing the display or keys with extreme force could damage the device.
- DO NOT use a pen or any sharp object to tap the screen.
- DO NOT expose the device to dirty or dusty environments.
- Use this device in the temperature range of 5 °C ~ 35 °C and humidity: 35% ~ 85%.
- Charge device in ambient temperature 5 °C ~ 35 °C; Internal Battery may leak/overheat and performance may deteriorate outside this range.
- DO NOT place the device on an uneven or unstable surface.
- DO NOT insert any foreign objects into the device.
- DO NOT expose the device to strong magnetic or electrical field.
- DO NOT use or store the device in a place where it will be exposed to high temperatures, such as near an open flame or heat-emitting equipment.
- Do not let the product submerged into or get wet with the liquids (seawater, water from a swimming pool, hot water of hot spring, water containing soap, detergent or bath powder, alcohol, soft drink, seasoning, Pet Body Fluids, etc.) other than tap water. If it gets wet, immediately rinse it with tap water.
- Refer to the device's rating label and be sure to use a charger that meets the rating. Use only the Accessory Device provided by the manufacturer.
- Prolonged use may cause the temperature of the Device to rise. If the Device appears too hot, avoid direct contact with the skin as this may cause discomfort or burns.
- Disconnect the device from an electrical outlet and power off before cleaning the device.
- NEVER attempt to connect or disconnect the charger with wet hands.
- Clean the touch screen with a soft cloth. If needed, dampen the cloth slightly before cleaning. Never use abrasives or cleaning solutions.
- DO NOT disassemble the device. Only a certified service technician should perform repair.
- Please check with your Local Authority or retailer for proper disposal of electronic products.
- For USB connection, users must use a USB 2.0 (or higher version) cable.
- The charger shall be installed near the equipment and shall be easily accessible.
- The temperature of the device might increase while the CPU is busy handling resource consuming activities such as high resolution video decoding. The SW protection mechanism will ensure stop charging whenever the temperature is over the predefined threshold and prepare for shut down if necessary. Please rest assured.
- Use a wireless hands-free system (headphone, headset) with a low power Bluetooth equipment.
- Keep your calls short or send a text message (SMS) instead. This advice applies especially to children, adolescents and pregnant women.
- People having active medical implants should preferably keep the device at least 15 cm away from the implant.
- Actual available capacity of user storage and internal memory is less because of the operating system, software and other functions which utilize part of this capacity. The available capacity may change with software updates.
- The wet body must not be charged.

- The security level of face recognition is lower than other methods of screen lock (Pattern, PIN, Password, etc.).
- The recognition rate of face recognition is not 100% accurate.
- The specified charger is not waterproof.
- The charger means AC charger in the document.
- The charger may become hot during charging. Do not keep the charger in contact with your body.

Safety Precautions for Battery Use

- The device battery can not be removed, please do not disassemble.
- There is the danger of explosion if disassemble by unauthorized personnel.
- Recycle or dispose used batteries according to the local regulations.

Road and Environmental Safety

- Turn off the device in areas with a potentially explosive atmosphere or where flammable objects exist such as gas stations, fuel depots, and chemical plants among others. Sparks from these areas could cause explosion or fire and result in injury or even death.
- Do not use devices while driving a vehicle. Use hands-free devices as an alternative.

Safety in Aircraft

Do not use the device on board an aircraft. The device's network signals may cause interference to the navigation system. As a safety measurement, it is prohibited to use devices on board in most countries.

Copyright Information

- Copyright© SHARP CORPORATION. 2012. All rights reserved.
- Android is a trademark of Google LLC.
- microSD™ is a trademark of SD Card Association.
- USB Type-C™ is a trademark of USB Association.
- LTE is a trademark of ETSI
- All products use in this device and trademarks mentioned herein are trademarks or registered trademarks of their respective owners.

Intellectual Property Right Information

The Bluetooth® word mark and logos are registered trademarks owned by Bluetooth SIG, Inc. and any use of such marks by SHARP CORPORATION is under license.



Wi-Fi®, the Wi-Fi CERTIFIED logo and the Wi-Fi logo are trademarks of Wi-Fi Alliance. All technologies and products used in this device are the intellectual property rights owned by individual owners.

THIS PRODUCT IS LICENSED UNDER THE AVC PATENT PORTFOLIO LICENSE FOR THE PERSONAL AND NONCOMMERCIAL USE OF A CONSUMER TO (i) ENCODE VIDEO IN COMPLIANCE WITH THE AVC STANDARD ("AVC VIDEO") AND/OR (ii) DECODE AVC VIDEO THAT WAS ENCODED BY A CONSUMER ENGAGED IN A PERSONAL AND NONCOMMERCIAL ACTIVITY AND/OR WAS OBTAINED FROM A VIDEO PROVIDER LICENSED TO PROVIDE AVC VIDEO. NO LICENSE IS GRANTED OR SHALL BE IMPLIED FOR ANY OTHER USE. ADDITIONAL INFORMATION MAY BE OBTAINED FROM MPEG LA, L.L.C. SEE [HTTP://WWW.MPEGLA.COM](http://www.mpegla.com)



Other Information

- Band: LTE FDD: B1/B3/B7/B8/B28; LTE TDD: B38/B40; 5G: n1/n78
- Connection: Wi-Fi IEEE 802.11 a/b/g/n/ac (2.4 GHz/5 GHz); Bluetooth 5.3; NFC; SIM: Dual SIM
- Waterproof: IPX5 / IPX7 / IPX9
- Dustproof: IP6X

Contents of Accessories

- Quick Start Guide (This document)
- AC Charger
- USB Cable

- Protection Film
- Protection Cover

Made in China
 Design Company : SHARP CORPORATION

Sales Company : SHARP Singapore Electronics Corporation Pte. Ltd.
 438B Alexandra Road #06-02
 Alexandra Technopark
 Singapore 119968

Complies with
 IMDA Standards
 DB00855

SAR Information

Your mobile device is a radio transmitter and receiver. It is designed not to exceed the limits for exposure to radio waves recommended by international guidelines. These guidelines were developed by the independent scientific organization ICNIRP and include safety margins designed to assure the protection of all persons, regardless of age and health. The guidelines use a unit of measurement known as the Specific Absorption Rate, or SAR. The SAR limit for mobile devices is 2 W/kg and the highest SAR value for this device when tested at the ear is 0.281 W/kg* and when worn on the body is 0.979 W/kg*. For body-worn operation, this mobile device has been tested and meets the RF exposure guidelines when used with an accessory containing no metal and positioning the handset a minimum of 5 mm from the body. Use of other accessories may not ensure compliance with RF exposure guidelines. As SAR is measured utilizing the device's highest transmitting power the actual SAR of this device while operating is typically below that indicated above. This is due to automatic changes to the power level of the device to ensure it only uses the minimum level required to reach the network. The World Health Organization has stated that present scientific information does not indicate the need for any special precautions for the use of mobile devices. They note that if you want to reduce your exposure then you can do so by limiting the length of calls or using a hands-free device to keep the mobile phone away from the head.

* The tests are carried out in accordance with international guidelines for testing.

Volume Level Caution



To prevent possible hearing damage, do not listen at high volume levels for long periods.

SHARP®

Warranty

Warranty Coverage

SHARP provides a Product Warranty Statement for legally authorized SHARP products purchased from SHARP or an authorized reseller. SHARP does not offer a worldwide repair warranty.

If the product fails to function properly under normal environmental conditions, it is covered by a one-year warranty, which is valid from the date of purchase of the device. And is only valid upon presentation of proof of purchase from the date of original purchase.

In the event of natural damage or failure within the Warranty Period that is not covered by the Exclusion of Liability, SHARP will provide you with free "Repair Service", and the Warranty Period for any repaired Machine will be the same as the Warranty Period of the original purchase of the machine. And will not be extended.

For repaired products that have exceeded the warranty period or have been damaged by human error, a three-month warranty is provided for the same problem. "Repair Service" refers to the provision of one-to-one replacement of parts in the defective machine in order to restore the normal operation of the machine; any defective parts that have been replaced become the property of SHARP; consumable and/or expendable items or parts such as: except for removable batteries as six (6) months. Consumable and/or expendable items or parts such as: except for removable batteries which are covered by a six (6) month warranty and non-removable batteries which are covered by a twelve (12) month warranty, other accessories, limited to cables, headphones, and power adapters (if supplied), are covered by a six (6) month warranty.

Disclaimer

The warranty is void when the serial number on the outer casing of the device has been torn off or improperly altered. Unauthorized removal or alteration of identification labels on parts of the machine with serial numbers will also void the warranty on those parts. SHARP Warranty will not apply to the machine under the following circumstances:

- (1) Failure of the machine due to improper use, negligent operation, improper installation and maintenance, disassembly or repair by persons not authorized by SHARP, or unauthorized modification of the product structure using parts or devices not supplied by SHARP, as determined by SHARP.
- (2) Improper courier transportation. (e.g., improper packaging materials or packaging methods to pack the machine or improper drop and collision during delivery.)
- (3) Damage to the machine caused by natural or man-made disasters. (e.g. typhoons, fires, floods, lightning, etc.)
- (4) Damage caused by accidents. (e.g. liquid splashing, chemical substances, high temperature environment, voltage surge, poor power supply, etc.)
- (5) Damage caused by natural wear and tear or third party software or poisoning.
- (6) The operating system of this product only supports official system updates, if users brush the ROM system of third-party vendors or modify the system file by cracking, it may lead to system instability as well as security risks and security threats.

SHARP does not provide data rescue and backup services for this product, and is not responsible for the loss of data in this product due to any factors. SHARP may inspect the Product and determine whether to repair or replace parts for products that have exceeded the warranty period or for which the warranty does not apply, and will pay for all repairs and replacements. Repair and replacement services will be charged at the discretion of SHARP. Return shipping and repair costs are the responsibility of the customer. During the warranty period for this series of products, SHARP shall not be liable to the purchaser for any damages or losses arising out of the use of this series of products, including but not limited to, loss of business, loss of profits, or loss of use of this series of products. This Warranty Statement or the use and performance of this product series shall not be liable for any damages whatsoever.